



## Discrete Logic Replacement

---

---

### An Enhanced MM5369 - 60 MHz Generator

---

---

*Author: Jim Nagy  
London Ontario  
email: nagy@wwdc.com*

#### OVERVIEW

I call my idea an 'MM5369E' as it represents the equivalent of a 5369 IC plus all the 'glue' necessary to sync-lock this 60 Hz generator to the power line.

Previously, I had used either the powerline or an MM5369 as a time base for my projects, but never both, as the circuits to detect missing pulses phase-lock the crystal to the line, and transfer between the two sources was just too complicated. Now it's all contained in an inexpensive 8-pin package.

As a bonus, I was able to include a divide-by-sixty circuit to provide a 1Hz output to further simplify time-keeping functions.

#### APPLICATION OPERATION

My circuit uses a standard 3.579545 MHz NTSC 'color burst' crystal for the main oscillator, just as the MM5369 does. This frequency is divided by 4 by the PIC12C508, then by 256 in the TMR0 prescaler, and counted in TMR0.

It works out that 233 counts of TMR0 and 11 more instruction cycles gives exactly four, 60 Hz periods. This fact is used to provide the 60 Hz output. (It's a little 'jittery' though, if viewed on a scope, as the four cycles are not exactly the same period. Phase jitter, however, is not important for this type of time-keeping function.) Every time that the 60 Hz output goes high, a counter is incremented as well, and this counter value is then used to drive the 1Hz output.

Sync-lock is achieved by allowing a high-to-low signal at GP2 to reset the main counter, TMR0. As long as these transitions occur, the output will continue to follow the input, and the output will have exactly the same frequency as the line frequency. As this is traceable back to national standards, it is better as a long-term reference than the crystal. As to deciding which source to use for the output, a very narrow window is set up to detect whether a 60 Hz sync pulse occurred before the timer timed out, or not. This allows an AC failure to be detected during the cycle that it failed, and a 3.58 MHz derived one to be inserted with no loss of output cycles. The narrow window does slow sync-lock down considerably, however, on return of AC, typically taking about 30 seconds to regain lock. (If the two frequencies were identical, but only differed in phase, the circuit could theoretically never return to sync-lock).

The synchronizing input is provided from either a half-wave or full-wave rectified 60 Hz source and is connected to the GP2 Schmitt trigger input through a current limiting resistor, so that peak inputs greater than the 5V supply can be used without damaging the input. The input must have a peak value of at least VDD (5V). This pin also has a large value resistor connected from it to VSS to provide a reference for floating inputs. No other special components are required for circuit operation.

---

Microchip Technology Incorporated, has been granted a nonexclusive, worldwide license to reproduce, publish and distribute all submitted materials, in either original or edited form. The author has affirmed that this work is an original, unpublished work and that he/she owns all rights to such work. All property rights, such as patents, copyrights and trademarks remain with author.

# Discrete Logic Replacement

## GRAPHICAL HARDWARE REPRESENTATION

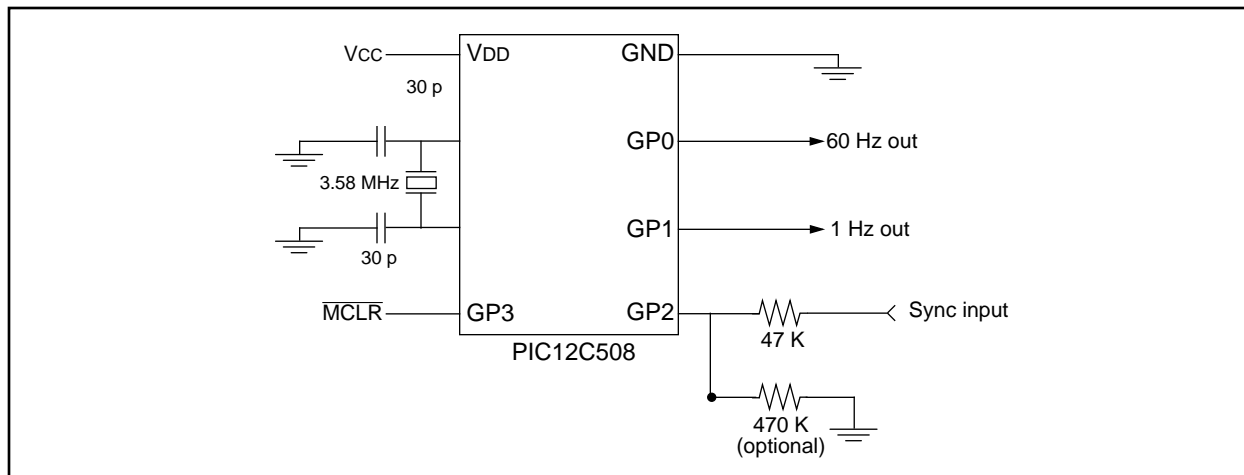

## BILL OF MATERIALS (BOM)

- PIC12C508
- 3.58 MHz Crystal
- 2 x 33 pF caps
- 1 x 47 K $\Omega$ , 1 x 470 K $\Omega$  resistors

# Discrete Logic Replacement

## APPENDIX A: SOURCE CODE

```
;
;
;           MM5369E
;           =====
;           by Jim Nagy, August 1997
;
;           A replacement circuit for the MM5369 60Hz generator, using the PIC12C508
;
;           In addition to providing a 60 Hz output from a 3.58MHz crystal,
;           this circuit also provides a 1Hz output, and a sync input.
;           The sync input provides better long term stability than the crystal,
;           as it uses the power line frequency (which is regularly corrected).
;           It can be either half-wave, or full-wave 60Hz, positive going.
;
;           Circuit connections are as follows:
;           - 60Hz output is from GP0 (pin 7)
;           - 1Hz output is from GP1 (pin 6)
;           - Sync input is on GP2 (pin 5), through a 47K $\Omega$  limiting resistor (a 470 K $\Omega$ 
;           resistor is connected from this pin to Vss, to ensure a ground reference)
;           - GP3 (pin 4) is configured as an active low MCLR, with internal pullup
;           - A 3.579545 MHz (color burst) crystal is connected to pins 2 and 3, with
;             33 pF capacitors from each pin to Vss as well.
;           - +5V is connected to pin 1, gnd to pin 8
;
;           *****
;
; Standard Equates
W           EQU 0
F           EQU 1

GPWUF      EQU 7
PA0        EQU 5
TO         EQU 4
PD         EQU 3
Z          EQU 2
Zero       EQU 2
DC         EQU 1
C          EQU 0
Carry      EQU 0

MCLRDisabled EQU 0
MCLREnabled  EQU H'10'
CodeProtect  EQU 0
NoCodeProtect EQU H'08'
WDTDisabled  EQU 0
WDTEnabled   EQU H'04'
IntrCOsc     EQU H'02'
ExtrCOsc     EQU H'03'
XTOSC        EQU H'01'
LPOsc        EQU 0

; '508 Registers
INDF        EQU H'00'
TMR0        EQU H'01'
PCL         EQU H'02'
STATUS      EQU H'03'
FSR         EQU H'04'
OSCCAL      EQU H'05'
GPIO        EQU H'06'

; program variables
Cycles      EQU H'07'           ; Cycle counter for 1 Hz output

;           Setting the ID words...
```

# Discrete Logic Replacement

---

---

```
                                ORG H'0200'
ID0                             Data.W      H'0000'
ID1                             Data.W      H'0000'
ID2                             Data.W      H'0000'
ID3                             Data.W      H'0007'

;                               and the Fuses...

                                ORG H'0FFF'
CONFIG Data.W                   MCLREnabled + NoCodeProtect + WDTEnabled + XTOSC

;                               *****
;                               PIC starts here on power up...
;                               *****

                                ORG H'00'

Init                             CLRWDT      ; setting up options...
                                MOVLW B'11000111' ; TMR0 uses int clock input, /256prescaler
                                OPTION        ; no pullups, and no wakeup on pin change
                                CLRF         GPIO
                                MOVLW B'00111100' ; Want GP0 and GP1 as outputs,
                                TRIS        GPIO ; others are inputs

                                CLRF         Cycles ; prime the 1 Hz counter
                                DECF        Cycles,F

Main                             CLRF        TMR0 ; start timing

;                               produce 1 cycle of 59 counts (16.88 msec)
Cycle1 BSF                       GPIO,0      ; set 60Hz output high
                                CALL        OneHz ; and service the 1 Hz output
c11                             CLRWDT      ; reset the watchdog
                                MOVLW D'30' ; wait for 30 cycles (8.6 msec) to pass
                                SUBWF TMR0,W
                                BTFSS      STATUS,Carry
                                GOTO       c11
                                BCF        GPIO,0 ; then set 60Hz output low

c12                             MOVLW D'36' ; wait to open the sync window, as
                                SUBWF TMR0,W ; sync may still be low due to jitter
                                BTFSS      STATUS,Carry
                                GOTO       c12

c13                             BTFSC      GPIO,2 ; check for a high sync input
                                GOTO       c14 ; and 'arm' the circuits if it is
                                CLRWDT      ; else, reset the watchdog
                                MOVLW D'59' ; and check for end of cycle
                                SUBWF TMR0,W
                                BTFSS      STATUS,Carry
                                GOTO       c13 ; and repeat until one of these occur
                                GOTO       Cycle2

c14                             BTFSS      GPIO,2 ; sync input was high, wait for lowinput
                                GOTO       Main ; and terminate this counter loop if it is
                                CLRWDT      ; else, reset the watchdog
                                MOVLW D'59' ; and check for end of cycle
                                SUBWF TMR0,W ; (sync may still be low due to jitter)
                                BTFSS      STATUS,Carry
                                GOTO       c14

;                               produce 1 cycle of 58 counts (16.59 msec)
Cycle2 BSF                       GPIO,0      ; set 60Hz output high
```

# Discrete Logic Replacement

```
c21      CALL      OneHz      ; and service the 1 Hz output
        CLRWDT          ; reset the watchdog
        MOVLW D'88'    ; wait for 29 cycles (8.3 msec) to pass
        SUBWF TMR0,W
        BTFSS        STATUS,Carry
        GOTO        c21
        BCF         GPIO,0      ; then set 60Hz output low

c22      MOVLW D'94'    ; wait to open the sync window
        SUBWF TMR0,W    ; (sync may still be low due to jitter)
        BTFSS        STATUS,Carry
        GOTO        c22

c23      BTFSC        GPIO,2    ; check for a high sync input
        GOTO        c24      ; and 'arm' the circuits if it is
        CLRWDT          ; else, reset the watchdog
        MOVLW D'117'   ; and check for end of cycle
        SUBWF TMR0,W
        BTFSS        STATUS,Carry
        GOTO        c23      ; and repeat until one of these occur
        GOTO        Cycle3

c24      BTFSS        GPIO,2    ; sync input was high, wait for lowinput
        GOTO        Main     ; and terminate this counter loop if it is
        CLRWDT          ; else, reset the watchdog
        MOVLW D'117'   ; and check for end of cycle
        SUBWF TMR0,W    ; (sync may still be low due to jitter)
        BTFSS        STATUS,Carry
        GOTO        c24

;
; produce 1 cycle of 58 counts (16.59 msec)
Cycle3 BSF      GPIO,0      ; set 60Hz output high
c31      CALL      OneHz      ; and service the 1 Hz output
        CLRWDT          ; reset the watchdog
        MOVLW D'146'   ; wait for 29 cycles (8.3 msec) to pass
        SUBWF TMR0,W
        BTFSS        STATUS,Carry
        GOTO        c31
        BCF         GPIO,0    ; then set 60Hz output low

c32      MOVLW D'152'   ; wait to open the sync window
        SUBWF TMR0,W    ; (sync may still be low due to jitter)
        BTFSS        STATUS,Carry
        GOTO        c32

c33      BTFSC        GPIO,2    ; check for a high sync input
        GOTO        c34      ; and 'arm' the circuits if it is
        CLRWDT          ; else, reset the watchdog
        MOVLW D'175'   ; and check for end of cycle
        SUBWF TMR0,W
        BTFSS        STATUS,Carry
        GOTO        c33      ; and repeat until one of these occur
        GOTO        Cycle4

c34      BTFSS        GPIO,2    ; sync input was high, wait for lowinput
        GOTO        Main     ; and terminate this counter loop if it is
        CLRWDT          ; else, reset the watchdog
        MOVLW D'175'   ; and check for end of cycle
        SUBWF TMR0,W    ; (sync may still be low due to jitter)
        BTFSS        STATUS,Carry
        GOTO        c34

;
; produce 1 cycle of 58 counts (16.59 msec) and ~11 cycles
; At this point, we've counted 59+58+58+58=233 cycles, or 66.654 msec.
; We only have to delay a few machine cycles before repeating all...
Cycle4 BSF      GPIO,0      ; set 60Hz output high
```

# Discrete Logic Replacement

---

```
c41      CALL      OneHz      ; and service the 1 Hz output
        CLRWDT      ; reset the watchdog
        MOVLW D'204'      ; wait for 29 cycles (8.3 msec) to pass
        SUBWF TMR0,W
        BTFSS      STATUS,Carry
        GOTO      c41
        BCF      GPIO,0      ; then set 60Hz output low

c42      MOVLW D'210'      ; wait to open the sync window
        SUBWF TMR0,W      ; (sync may still be low due to jitter)
        BTFSS      STATUS,Carry
        GOTO      c42

c43      BTFSC      GPIO,2      ; check for a high sync input
        GOTO      c44      ; and 'arm' the circuits if it is
        CLRWDT      ; else, reset the watchdog
        MOVLW D'233'      ; and check for end of cycle
        SUBWF TMR0,W
        BTFSS      STATUS,Carry
        GOTO      c43      ; and repeat until one of these occur
        GOTO      Main

c44      BTFSS      GPIO,2      ; sync input was high, wait for lowinput
        GOTO      Main      ; and terminate this counter loop if it is
        CLRWDT      ; else, reset the watchdog
        MOVLW D'233'      ; and check for end of cycle
        SUBWF TMR0,W      ; (sync may still be low due to jitter)
        BTFSS      STATUS,Carry
        GOTO      c44
        GOTO      Main

;
; *****
; OneHz - routine to service the 1Hz system

OneHz    INCF      Cycles,F      ; the output has just gone high -count it
        MOVLW D'30'
        SUBWF Cycles,W      ; compare count to 30
        BTFSC      STATUS,Carry
        GOTO      GT29
        BSF      GPIO,1      ; 0<count<30, set output high
        RETLW 0

GT29     MOVLW D'60'      ; we're >29, but may be 60...
        SUBWF Cycles,W      ; compare count to 60
        BTFSC      STATUS,Carry
        GOTO      GT59
        BCF      GPIO,1      ; 29<count<60, set output low
        RETLW 0

GT59     CLRF      Cycles      ; reset cycle counter, then
        BSF      GPIO,1      ; set output high
        RETLW 0

END
```