

Metal Hands

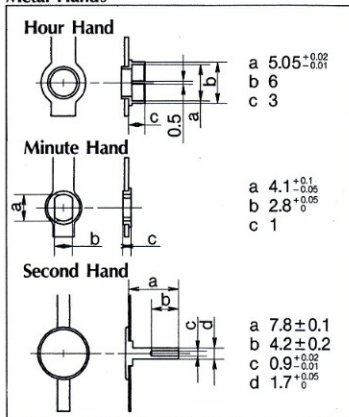

*Fixing torque: Center nut $\leq 30\text{kg}\cdot\text{cm}$
Minute hand nut $\leq 1\text{kg}\cdot\text{cm}$

*Press force of hands: Second hand: $\leq 10\text{kg}$
Hour hand $\leq 5\text{kg}$

*In case of plastic hands, the diameters should be smaller than the above.

| Shaft Length | A | B | C | D |
|--------------|------|------|------|------|
| Cal. | | | | |
| 28504R | 8.8 | 12.5 | 15.5 | 16.5 |
| 28506R | 4.5 | 9.9 | 12.5 | 13.9 |
| 28507R | 19.0 | 22.5 | 25.8 | 26.5 |
| 28909R | 4.5 | 8.0 | 11.0 | 12.0 |
| 28008S | 14.0 | 17.5 | 20.8 | 21.5 |

Accessory Parts

- Hanger
- Center Nut
- Center Nut Washer
- Minute Hand Nut